

TECHNICAL DETAILS

Overlay Estate Stone

PRODUCT DRAWINGS

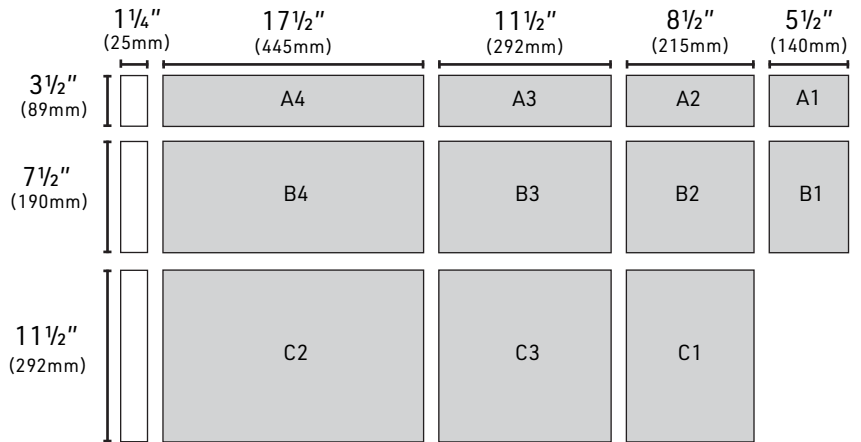
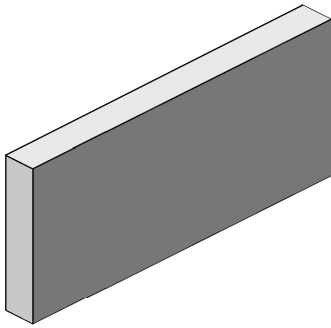

Piece Ratios

Unit	A1	A2	A3	A4	B1	B2	B3	B4	C1	C2	C3	Total: 24
Quantity	3	4	4	3	2	2	1	2	1	1	1	

PRODUCT DETAILS

	Overlay Estate Stone		Overlay Estate Stone Corner	
	Metric	Imperial	Metric	Imperial
Selling UoM		SF		LF
Coverage/Skid	11.9m ²	128sf	6.96m ²	75sf
Weight/UoM	52.4kg	10.7lbs	6.8kg	15lbs
Weight/Piece	N/A	N/A	N/A	N/A
Weight/Skid	641kg	1,410lbs	530kg	1,165lbs
Pieces/Skid	N/A	N/A	N/A	N/A
# of Layers	N/A	N/A	N/A	N/A
Pieces/Layer	N/A	N/A	N/A	N/A
UoM/Layer	N/A	N/A	N/A	N/A
Pieces/UoM	N/A	N/A	N/A	N/A
Pallet Size	122cmx106cm	48"x42"	122cmx106cm	48"x42"

CORNERS

Corner units are sold seperately.

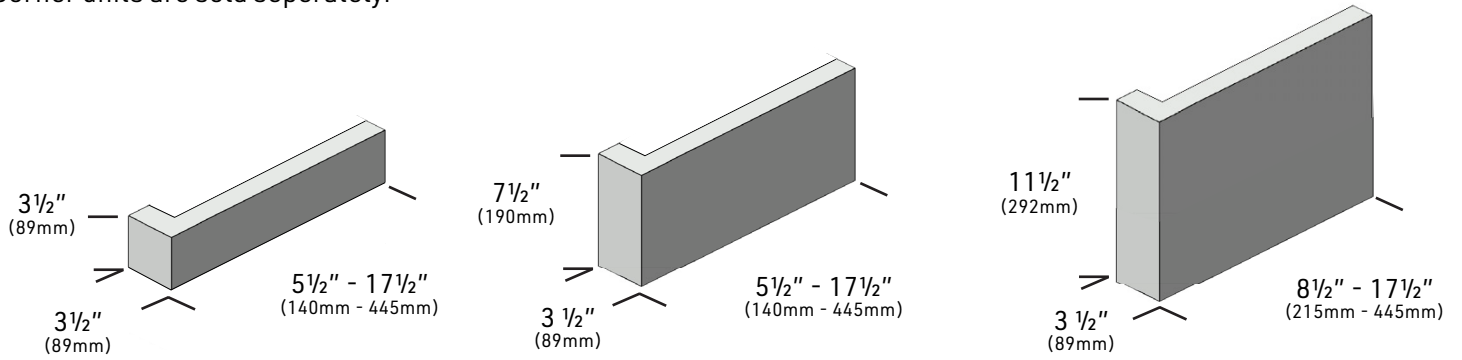

TYPICAL INSTALLATION PATTERN

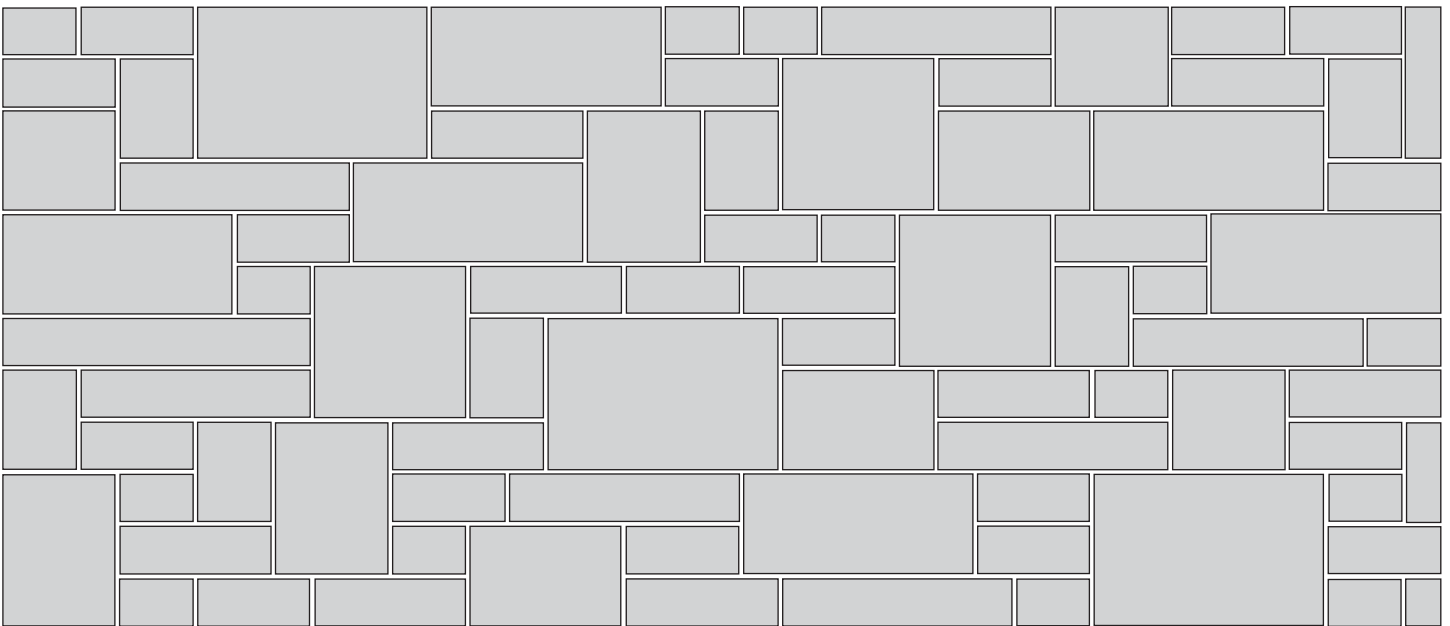

- Typical Installation Guidelines:
- Blend product from multiple packages for most natural look
 - 6 foot Max Horizontal joint length
 - 12 inch Max Vertical joint height

TYPICAL MORTAR JOINT

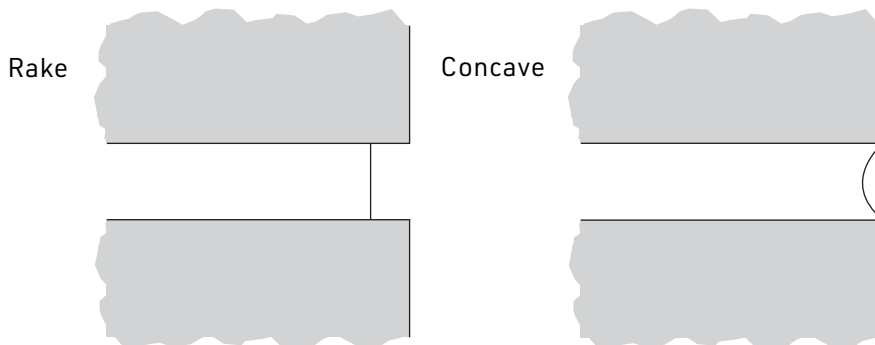

Recomended Mortar Joint 13mm (1/2")

TYPICAL COURSING GUIDE

Table includes one unit considered as 3 ½" plus ½" joint

Vertical Units	12mm Joint	½" Joint
1	101mm	4"
2	202mm	8"
3	303mm	12"
4	404mm	16"
5	505mm	20"
6	606mm	24"
7	707mm	28"
8	808mm	32"
9	909mm	36"
10	1,010mm	40"
20	2,020mm	80"
30	3,030mm	120"
40	4,040mm	160"
50	5,050mm	200"
100	10,100mm	400"

CODES & STANDARDS

Shouldice Stone Products are supported by the following National Codes & Standards.
Refer to local building codes and standards to confirm best practice.

CANADIAN

CSA A165 Standards on Concrete Masonry Units
CSA A179 Mortar and Grout for Unit Masonry

AMERICAN

NCMA MSV Compliance with ASTM C1780
ASTM C270 Specification for Mortar for Unit Masonry
ASTM C1634 Specification for Concrete Facing Brick and Other Concrete Masonry Facing Units
ASTM C847 Standard Specification for Surface Applied Bonding Compounds for Exterior Plastering
ASTM C933 Standard Specification for Welded Wire Lath
ASTM C1059/1059M Standard Specification for Latex Agents for Bonding Fresh to Hardened Concrete
ASTM C1670/C1670M Standard Specification for Adhered Manufactured Stone Masonry Veneer Units
ASTM C1780 Standard Practice for Installation Methods for Adhered Manufactured Stone Masonry Veneer

NCMA TEK 8-4A Cleaning Concrete Masonry
NCMA TEK 9-1A Mortars for Concrete Masonry
NCMA TEK 8-3A Control and Removal of Efflorescence

TYPICAL UNIT PROPERTIES

Products exceed the CSA and ASTM standards.

	Standard	Compression Strength	Absorption	Density
CSA	A165-04	>25mpa	<8%	>2000kg/m ²
ASTM	C1634	>3000psi	<12lb/ft ³	>125lb/ft ³

HATCH PATTERNS & TEXTURE MAPS

To access Shouldice Stone Hatch Patterns and texture maps visit the corresponding [shouldice.ca product page](#) for current availability.

CONTACT US

For technical questions regarding our product line please contact our knowledgeable customer service team. By phone: **800.265.3174** or email: **designer@shouldice.ca**